



Mini Trans-Blot[®] Electrophoretic Transfer Cell

Instruction Manual

Catalog Numbers

170-3930

170-3935



Note

Assembly and Disassembly

To insure best performance from the Mini Trans-Blot electrophoretic transfer cell, become fully acquainted with these operating instructions before using the cell to transfer samples. Bio-Rad recommends that you first read these instructions carefully. Then assemble and disassemble the cell completely. After these preliminary steps, you should be ready to transfer a sample.

Wash Cell Before Use

Bio-Rad also recommends that all Mini Trans-Blot electrophoretic transfer cell components and accessories be cleaned with a suitable laboratory cleaner (such as Bio-Rad Cleaning Concentrate, catalog number 161-0722) and rinsed thoroughly with distilled water, before use.

Warranty

Model _____

Catalog Number _____

Date of Delivery _____

Warranty Period _____

Serial Number _____

Invoice Number _____

Purchase Order Number _____

Bio-Rad Laboratories warrants the Mini Trans-Blot electrophoretic transfer cell against defects in materials and workmanship for 1 year. If any defects occur in the instrument during this warranty period, Bio-Rad Laboratories will repair or replace the defective parts free. The following defects, however, are specifically excluded:

1. Defects caused by improper operation.
2. Repair or modification done by anyone other than Bio-Rad Laboratories or an authorized agent.
3. Use of fittings or other spare parts supplied by anyone other than Bio-Rad Laboratories.
4. Damage caused by accident or misuse.
5. Damage caused by disaster.
6. Corrosion due to use of improper solvent or sample.

For any inquiry or request for repair service, contact Bio-Rad Laboratories after confirming the model and serial number of your instrument.

Table of Contents

Section 1	Introduction	1
1.1	Specifications	2
1.2	Safety Instructions.....	3
Section 2	Mini Trans-Blot Cell Assembly and Preparation for Transfer	4
2.1	Mini Trans-Blot Cell Description and Assembly.....	4
2.2	Preparation for Blotting.....	5
2.3	Acidic Transfers	8
Section 3	Transfer Conditions	8
3.1	General Guide for Transfer Buffers and Running Conditions.....	8
3.2	Notes on Electrophoretic Transfer Conditions	10
3.3	Buffer Formulation.....	11
Section 4	Strategies for Optimizing Electrophoretic Transfer	12
4.1	Optimizing Protein Transfer	12
4.2	Optimizing DNA and RNA Transfer.....	13
Section 5	Choice of Blotting Membranes	14
5.1	Protein Blotting Membranes	14
5.2	DNA and RNA Blotting Membranes	14
Section 6	Troubleshooting Guide	15
6.1	Electrophoretic Transfer.....	15
6.2	Immune-Specific Detection	18
6.3	Total Protein Detection	20
Section 7	Product Information	23
Section 8	References	23

Section 1 Introduction

Blotting was first performed by Southern in 1975 with the transfer of DNA from agarose gels to nitrocellulose membranes.¹ Since that time, blotting has been applied to RNA²⁻⁴ and proteins^{5, 6} in both agarose and polyacrylamide gels. To circumvent the inefficiencies observed in various capillary transfers, electric current has been adopted for eluting proteins from polyacrylamide gels, as first described by Towbin *et al.* in 1979.⁷ The use of electrophoretic transfer has also been applied to DNA and RNA blotting.^{8-13, 30} Numerous publications have dealt with the topic of protein electrophoretic transfer techniques.¹⁴⁻²⁵ There have also been reviews summarizing the expanding literature being generated on electrophoretic blotting methodology.^{26, 27, 31} For a more comprehensive listing of references and applications, refer to bulletin 1721, or in the US call Bio-Rad's Technical Services Group in Hercules, California toll free at 1-800-4BIORAD (1-800-424-6723).

The Mini Trans-Blot cell is one component of Bio-Rad's Modular Mini Electrophoresis System. This system includes the Mini-PROTEAN® II dual slab cell for running SDS-PAGE electrophoresis gels, the Mini Tube Cell for running first dimension IEF tube gels for 2-D applications, and the Model 422 Electro-Eluter for rapid, efficient recovery of proteins and nucleic acids from electrophoresis gels. The unique feature of this electrophoresis system is that the electrode modules are interchangeable. After finishing one task, remove the electrode module from the buffer tank, insert a new electrode module, add a new buffer, and the next electrophoresis application can be performed.

The Mini Trans-Blot module accommodates two cassettes for electrophoretic transfer of both gels generated by the Mini-PROTEAN II cell. The Mini Trans-Blot module is useful for blotting either protein or nucleic acid samples from both agarose and acrylamide gels. It is also capable of blotting isoelectric focusing gels run on horizontal electrophoresis cells, or DNA and RNA gels from the Mini-Sub® submarine electrophoresis cell. For applications where the gel is larger than 7.5 x 10 cm, or when there are many gels to be transferred, the larger standard Trans-Blot® cell (catalog number 170-3910 or 170-3946) or the Trans-Blot SD semi-dry cell (catalog number 170-3940) should be used.

The heart of the Mini Trans-Blot cell is its electrode module. This module has the capacity to hold two gel cassettes between parallel electrodes only 4 cm apart. The driving force for blotting applications is the voltage applied over the distance between the electrodes. This short 4 cm electrode distance allows generation of higher driving forces to produce efficient protein transfers. A second feature of the electrode module is that it is offset to accommodate a Bio-Ice cooling unit. The cooling unit, which is completely contained within the Mini Trans-Blot cell, absorbs the Joule heat generated during rapid electrophoretic transfers. The advantages of having an internal cooling unit include elimination of an expensive external cooling bath and avoidance of cumbersome cooling tubing that always seems to be in the way. Other features of the Mini Trans-Blot cell include latches on the gel holder cassettes for easy handling, color coordinated cassettes and electrodes to insure proper orientation of the gel during transfer, and an efficient design which simplifies insertion and removal of the cassettes from the electrode assembly. The result of these features is an electrophoretic transfer system which is easy to use, and which produces excellent blotting results.

1.1 Specifications

Construction

Electrode module	Molded polysulfone
Gel holder cassettes	Molded polycarbonate
Electrodes	Platinum wire 0.254 mm diameter
Buffer chamber and lid	Molded polycarbonate
Cooling unit	Polyethylene

Overall dimensions

Mini Trans-Blot cell	16 cm (L) x 12 cm (W) x 18 cm (H)
Gel holder dimensions	10 cm x 11 cm

Maximum gel size

7.5 cm x 10 cm

Buffer capacity

With cooling unit	650 ml
Without cooling unit	850 ml

Cleaning

Use mild soap and warm water to clean the electrodes, cassettes, and buffer tank. Use special care when cleaning the electrode cards or plate electrodes. Avoid stretching or breaking the platinum wires. Avoid scratching or marring the platinum plate. Do not use abrasives or strong detergents. The cathode plate (stainless steel) can be cleaned with a mild abrasive to remove salt that may be deposited during normal operation. Rinse the fiber pads under hot water and then in distilled, deionized water.

Chemical compatibility

The Mini Trans-Blot cell components are not compatible with chlorinated hydrocarbons (*e.g.*, chloroform), aromatic hydrocarbons (*e.g.*, toluene, benzene), or acetone. **Use of organic solvents voids all warranties.**

1.2 Safety Instructions



Power to the Mini Trans-Blot cell is supplied by an external DC voltage power supply. This power supply must be ground isolated in such a way that the DC voltage output floats with respect to ground. All of Bio-Rad's power supplies meet this important safety requirement. Regardless of which power supply is used, the maximum specified operating parameters for the cell are:

150 VDC		Maximum voltage limit
40 Watts		Maximum power limit
50 °C		Maximum ambient temperature limit



Current to the cell, provided from the external power supply, enters the unit through the lid assembly, providing a safety interlock to the user. Current to the the cell is broken when the lid is removed. **Do not attempt to circumvent this safety interlock, and always turn the power supply off before removing the lid, or when working with the cell in any way.**

Important: This Bio-Rad instrument is designed and certified to meet IEC 1010-1* safety standards. Certified products are safe to use when operated in accordance with the instruction manual. This instrument should not be modified or altered in any way. Alteration of this instrument will:

- **Void the manufacturer's warranty**
- **Void the IEC1010-1 safety certification**
- **Create a potential safety hazard**

Bio-Rad is not responsible for any injury or damage caused by the use of this instrument for purposes other than for which it is intended or by modifications of the instrument not performed by Bio-Rad or an authorized agent.

* IEC 1010-1 is an internationally accepted electrical safety standard for laboratory instruments.

Section 2 Mini Trans-Blot Cell Assembly and Preparation for Transfer

2.1 Mini Trans-Blot Cell Description and Assembly of Parts

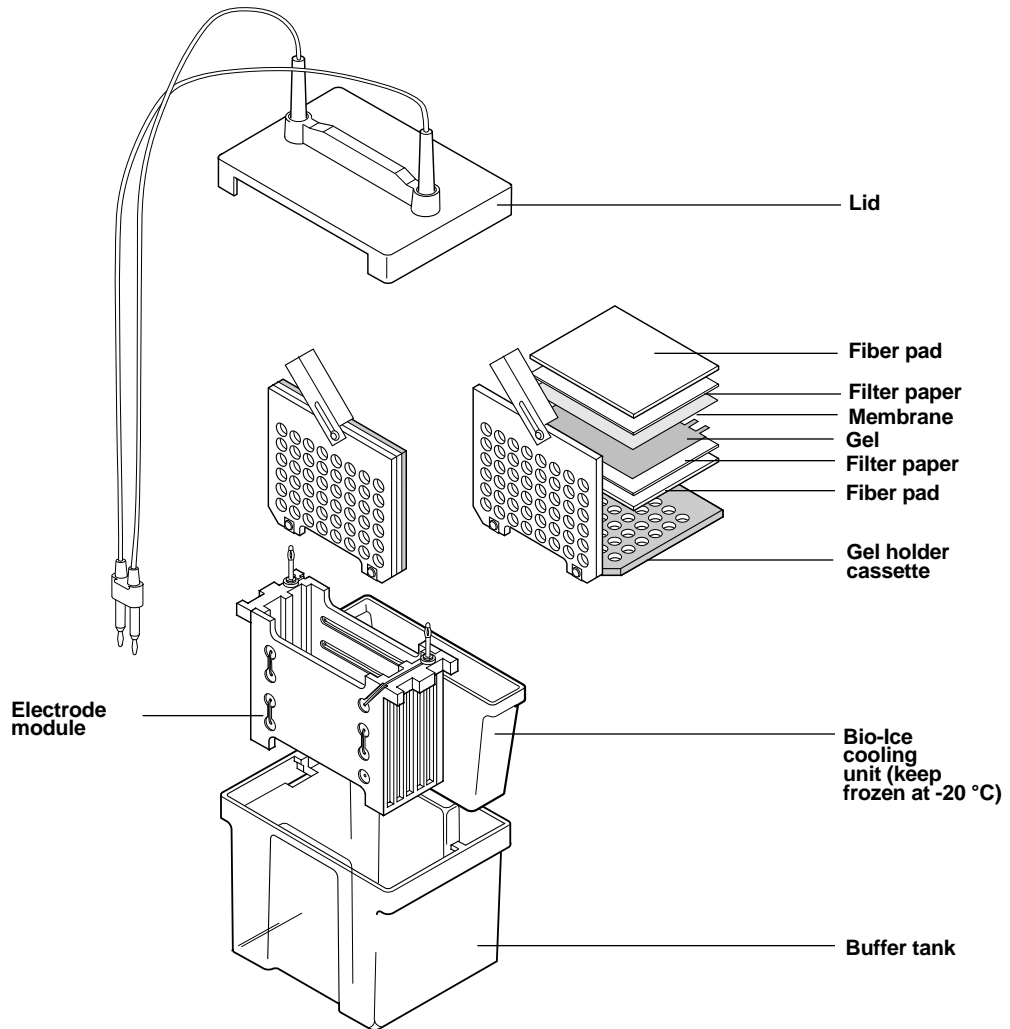

2.2 Preparation for Blotting

Fill the Bio-Ice cooling unit with water and store it in your laboratory freezer at $-20\text{ }^{\circ}\text{C}$ until ready to use. After use, return the cooling unit to the freezer for storage.

1. Prepare the transfer buffer. (See Section 3.3 for buffer formulation. Using buffer chilled to $4\text{ }^{\circ}\text{C}$ will improve heat dissipation.)

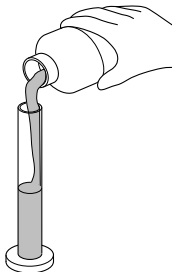

2. Cut the membrane and the filter paper to the dimensions of the gel. Always wear gloves when handling membranes to prevent contamination. Equilibrate the gel and soak the membrane, filter paper, and fiber pads in transfer buffer (15 min–1 hour depending on gel thickness).

3. Prepare the gel sandwich.

Place the cassette, with the gray side down, on a clean surface.

Place one pre-wetted fiber pad on the gray side of the cassette.

Place a sheet of filter paper on the fiber pad.

Place the equilibrated gel on the filter paper.*

Place the pre-wetted membrane on the gel.*

Complete the sandwich by placing a piece of filter paper on the membrane.*

Add the last fiber pad.

* Removing any air bubbles which may have formed is very important for good results. Use a glass tube to gently roll air bubbles out.

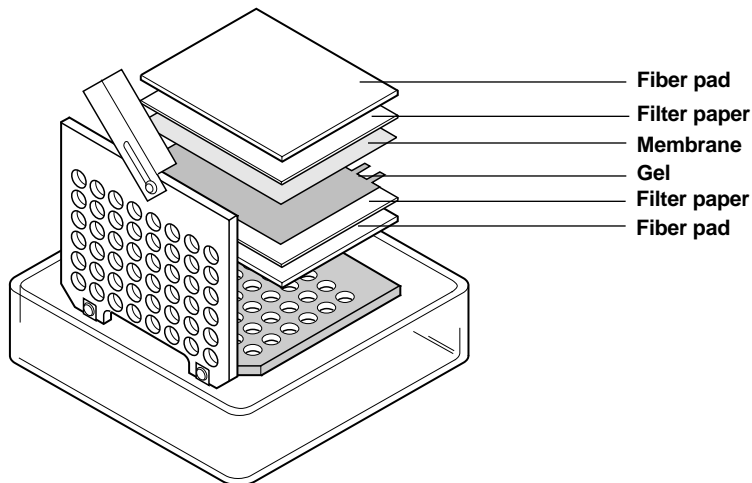

4. Close the cassette firmly, being careful not to move the gel and filter paper sandwich. Lock the cassette closed with the white latch.
5. Place the cassette in module. Repeat for the other cassette.

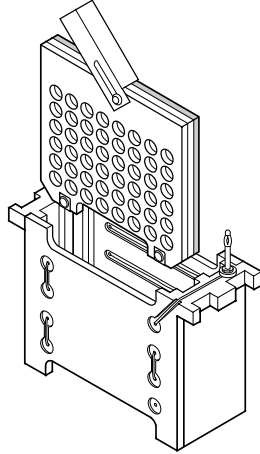

6. Add the frozen Bio-Ice cooling unit. Place in tank and completely fill the tank with buffer.

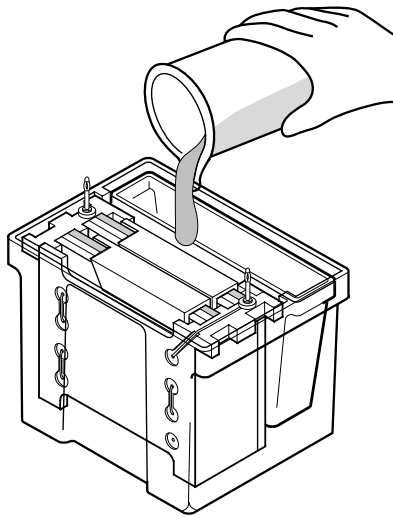

7. Add a standard stir bar to help maintain even buffer temperature and ion distribution in the tank. Set the speed as fast as possible to keep ion distribution even.

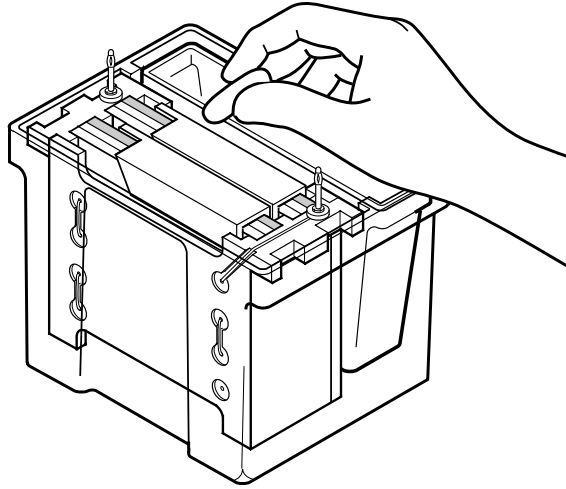

8. Put on the lid, plug the cables into the power supply, and run the blot. Refer to Section 3 for run times and voltage settings with various buffers.

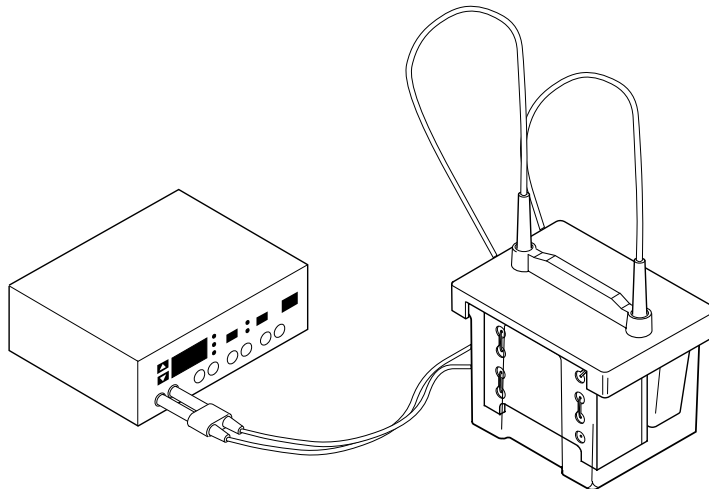

9. Upon completion of the run, disassemble the blotting sandwich and remove the membrane for development. Clean the cell, fiber pads, and cassettes with laboratory detergent and rinse well with deionized water.

2.3 Acidic Transfers

If transferring under acidic conditions, switch the gel and membrane in the set up instructions. This will place the membrane on the cathode side of the gel. Under acidic conditions, proteins will transfer in the opposite direction going toward the negative cathode. **Do not reverse the electrodes themselves.** This will cause damage to the instrument.

Section 3 Transfer Conditions

3.1 General Guide for Transfer Buffers and Running Conditions

Table 3.1 provide guidelines for power conditions using different buffers. Power conditions are provided for various run times. Where multiple conditions are displayed, the higher the voltage, the less time required for the run. Always use the Bio-Ice cooling unit.

Table 3.1. Guide to Buffers and Running Conditions

Buffer	Standard Field Overnight Transfer	High Intensity Field 4 cm electrode distance 1 Hour Transfer
SDS-PAGE Gels	Buffer A or B or C	Buffer A or B or C
A: 25 mM Tris, pH 8.3, 192 mM glycine, with or without 20% MEOH and .025%–0.1% SDS.	30 V 90 mA	100 V 350 mA
B: 48 mM Tris, pH 9.2, 39 mM glycine, with or without 20% MEOH and .025%–0.1% SDS.		
C: 10 mM NaHCO ₃ , 3 mM NaCO ₃ , pH 9.9, with or without 20% MEOH and .025%–0.1% SDS.		
DNA and RNA		
TAE: 20 mM Tris, pH 7.8, 10 mM sodium acetate, 0.5 mM EDTA	30 V 100 mA	80 V 500 mA
TBE: 50 mM Tris, pH 8.3, 50 mM sodium borate, 1.0 mM EDTA		
Native Gels		
25 mM Tris, pH 8.3, 192 mM glycine. No methanol.	30 V 90 mA	100 V 350 mA
Isoelectric Focusing, Native Gels, Basic Proteins, Acid Urea Gels		
0.7% acetic acid	30 V 100 mA	100 V 350 mA

3.2 Notes on Electrophoretic Transfer Conditions

These variables will change total resistance and thus the current readings:

- Alterations in buffer make-up, *i.e.*, addition of SDS, or changes in ion concentration due to addition of acid or base to adjust the pH of the buffers.
- Gel pH, ionic strength, and percentage of acrylamide, especially if the gel has not been properly equilibrated.
- Number of gels; current increases slightly as the number of gels increases.
- Volume of buffer; current increases when volume increases.
- Platinum mass; current increases when mass increases.
- Transfer temperature; current increases when temperature increases.
- Time in transfer at which reading was taken; current normally increases as the buffering capacity diminishes with progress of the run.

Pre-equilibration of gels

All electrophoresis gels should be pre-equilibrated in transfer buffer prior to electrophoretic transfer. Pre-equilibration will facilitate the removal of contaminating electrophoresis buffer salts and neutralization salts (salts resulting from the denaturation of nucleic acids prior to transfer). If the salts are not removed, they will increase the conductivity of the transfer buffer and the amount of heat generated during the transfer. Also, low percentage gels (<12%) will shrink in methanol buffers. Equilibration allows the gel to adjust to its final size prior to electrophoretic transfer.

Current limits

The PowerPac 200 Power Supply is capable of a 200 watt output. Unless a current limit is set, uncontrolled conductivity changes may result in full power being delivered to the Mini Trans-Blot cell. The gel holders may warp, and the transfer buffer may boil and evaporate (further increasing conductivity). This would result in a potential safety hazard. Refer to the PowerPac 200 Power Supply Instruction Manual for setting current limits and run times.

Polarity of transfer

Do not reverse polarity with the plate electrodes.

Use of a stir bar during transfer

For all blotting applications a stir bar must be placed inside the Mini Trans-Blot cell, so that the transfer buffer is stirred during the course of the experiment. This will help to maintain uniform conductivity and temperature during electrophoretic transfer. Failure to properly control transfer buffer temperature results in poor transfer of macromolecules and poses a potential safety hazard.

Transfer buffer pH

Do not adjust the pH of transfer buffers unless specifically indicated. Adjustments of the pH of transfer buffers, when not indicated, will result in increased buffer conductivity. This is manifested by a higher than expected initial current output and a decreased resistance. It is recommended that the buffer conductivity and resistance be checked with the PowerPac 200 Power Supply before starting each transfer.

Transfer buffer recommendations

Use only high quality, reagent grade methanol. Contaminated methanol can result in increased transfer buffer conductivity, as well as poor transfer of macromolecules. Do not reuse transfer buffers or dilute transfer buffers below recommended levels. Reuse of transfer buffers is not advised, since these buffers have most likely lost their ability to maintain a stable solution pH during transfer. Dilution of transfer buffers below their recommended levels is also not advised, since this will decrease their buffering capacity.

Voltage limits

Do not increase voltage settings beyond those indicated in Tables 3.1–3.4 for overnight operation. Buffer conductivity must be close to the current listed and a current limit should be set on the power supply. If overnight transfers at low voltages are ineffective for your application, and higher voltages are necessary, transfer times must also be decreased. Failure to do so may result in a potential safety hazard.

3.3 Buffer Formulation

All formulas provided below are for a total volume of 1 liter of buffer. Approximately 500 ml of buffer are required for the Mini Trans-Blot cell.

Do not add acid or base to adjust pH of the following buffers. Methanol should be analytical reagent grade, as metallic contaminants in low grade methanol will plate on the electrodes.

Note: Some pH electrodes will not perform a proper measurement for the pH of Tris buffers. If the pH of the buffer is off, check to make sure the electrode is designed to work with Tris buffers. If the pH electrode functions properly for Tris buffers and the pH is below 8.0, remake the buffer.

25 mM Tris, 192 mM glycine, 20% v/v methanol, pH 8.3

Mix 3.03 g Tris, 14.4 g glycine, and 200 ml of methanol; add distilled deionized water (dd H₂O) to 1 liter.

25 mM Tris, 192 mM glycine, pH 8.3

Mix 3.03 g Tris and 14.4 g glycine; add dd H₂O to 1 liter.

48 mM Tris, 39 mM glycine, 20% v/v methanol, pH 9.2

Mix 5.82 g Tris and 2.93 g glycine in ddH₂O, add 200 ml methanol
Bring to 1 liter with ddH₂O

48 mM Tris, 39 mM glycine, pH 9.2

Mix 5.82 g Tris and 2.93 g glycine
Add ddH₂O to 1 liter

10 mM NaHCO₃, 3 mM NaCO₃, 20% methanol, pH 9.9

Mix 0.84 g NaHCO₃ and 0.318 g NaCO₃ in ddH₂O, add 200 ml methanol
Bring to 1 liter with ddH₂O

1.0x TBE (Tris-Borate EDTA), pH 8.3

90 mM Tris-Borate 1 mM EDTA

5x stock solution

54 g Tris base

27.5 boric acid

20 ml 0.5 M EDTA (pH 8.0)

Add 200 ml 5x stock to 800 ml ddH₂O to make 1.0x working solution.

1x TAE (Tris-Acetate EDTA)

40 mM Tris-Acetate 1 mM EDTA

50x stock solution

242 g Tris base

57.1 ml glacial acetic acid

100 ml 0.5 M EDTA (pH 8.0)

1x working solution, add 20 ml 50x stock to 980 ml ddH₂O

Section 4 Strategies for Optimizing Electrophoretic Transfer

4.1 Optimizing Protein Transfer

Generally, quantitative elution of denatured high molecular weight proteins is difficult. The following tactics, alone or in combination, will increase transfer efficiency.

Vary gel composition

Gradient gels are often more effective than single gel concentrations for elution of a wide range of molecular weight proteins.

Lower the total monomer to create a more porous gel.

Increase or decrease the percentage of crosslinker. A 5.26% C gel will contain the smallest pore size of all gels no matter what the concentration of acrylamide. An increase or decrease in %C will make gels more porous with little loss in resolution.

$$\%C = \frac{\text{grams bis}}{\text{grams bis} + \text{grams acrylamide}} \times 100$$

Increase transfer time

An initial control should be performed to determine the time required for complete transfer.^{17,24} Times may vary from as little as 30 minutes to as long as overnight. Remember all overnight applications should be performed at 30 volts to minimize heating problems.

Increase the power

Initial controls should be performed to evaluate the efficiency of increasing the V/cm as well as its effects on the temperature of transfer. The temperature increase may change buffer resistance and subsequent power delivered, as well as the state of protein denaturation, thus affecting transfer efficiency.

Reduce buffer strength

Dilution of transfer buffer results in lower current at any given voltage. This will allow the use of higher voltages without excessive heating.

Vary buffer type and pH

Maximize charge-to-mass ratio. It appears that alcohols present in SDS transfer buffer strip SDS from proteins. Basic proteins in Tris, glycine, methanol buffer at pH 8.3 may assume a state near isoelectric neutrality and thus transfer poorly. For example, lysozyme exhibits this behavior. Buffers with pH of 9.5 to 10.0 have shown much better elution and binding characteristics for basic proteins such as lysozyme and histones.⁴¹

Different buffer types at similar V/cm may yield different efficiencies. Generally Tris buffers allow more efficient transfer than acetate or phosphate buffers.

Add detergent

Addition of 0.1% SDS detergent to Tris, glycine, methanol buffer has been reported to increase transfer efficiency.²⁴ SDS, however, increases relative current, power, and heating. Also, temperatures below 10 °C may precipitate the SDS so the starting buffer temperature will be higher. SDS may also affect the antigenicity of some proteins. SDS will aid in eluting the proteins from the gel, but it may reduce the binding efficiency of those proteins to the nitrocellulose membrane.⁴²

Eliminate alcohol from the transfer buffer

Alcohol in the transfer buffer improves binding of SDS proteins to nitrocellulose only. Elimination of alcohol results in increased transfer efficiency but diminishes binding to nitrocellulose. Transfer efficiency is increased because alcohol causes gel pores to contract resulting in fixation of large molecular weight proteins within the gel matrix. Use of PVDF membrane for SDS protein transfers eliminates the alcohol requirement, and constitutes a logical strategy for analysis of high molecular weight or difficult-to-transfer proteins.^{26, 27} PVDF must be wetted in 100% methanol but may then be used in buffer without menanol.

Limited protease treatment

A protocol for protease digestion of protein during transfer has been published.²² Efficient transfer without loss of immunological reactivity was reported.

Alter membrane type

As mentioned in 7, PVDF membrane allows transfer in the absence of alcohol.

Alter gel system

If possible, use non-denaturing gradient pore gels for separation of proteins by molecular weight. Isoelectric focusing gels, or native gels, may be considered if separation by molecular weight is not mandatory.

Enhance gel-membrane contact

Failure of molecules to bind efficiently to the membrane, caused by poor gel-membrane contact, is often confused with inefficient elution. Poor contact is usually due to excess moisture in the gel-membrane interface. Proper technique and the use of a test tube or glass pipet as a “rolling pin” should assure good contact. Proper selection of filter paper spacers will help assure good compression. Gel and membrane equilibration in transfer buffer for 30 minutes to 1 hour prior to transfer will help prevent shrinking of either component during transfer, and will eliminate reactants such as urea or SDS from the gel.

4.2 Optimizing DNA and RNA Transfer

Problems with elution of nucleic acids can be solved by altering the gel percentage. It may be somewhat more difficult to quantitatively transfer large amounts of DNA used in genomic blots. The following tactics should be considered for optimizing elution in such transfers.

Alter gel composition

Lower % total monomer or % crosslinker for polyacrylamide gels.

Lower % agarose. This allows better elution of high molecular weight DNA.

Alter DNA denaturants

It has been found that glyoxal denaturation allows more efficient elution of DNA than NaOH. Boiling polyacrylamide gels to denature DNA has also been found to give excellent results.¹¹ Base denaturation often causes polyacrylamide gels to weaken and stick to blotting membranes.

Section 5 Choice of Blotting Membranes

5.1 Protein Blotting Membranes

Nitrocellulose Membrane

Nitrocellulose membranes have been used extensively for protein binding and detection.^{7,20,23,24,27} They can be easily stained for total protein by a dye stain (Amido Black, Coomassie® Blue, Ponceau S, Fast Green FCF, etc.),²⁷ or the more sensitive Colloidal Gold Total Protein Stain, and also allow either RIA, FIA or EIA.⁷ Nitrocellulose has a high binding capacity of 80–100 µg/cm². Nonspecific protein binding sites are easily and rapidly blocked, avoiding subsequent background problems. No pre-activation is required. Low molecular weight proteins (especially <20,000 daltons) may be lost during post transfer washes, thus limiting detection sensitivity.¹⁹ Smaller pore size nitrocellulose membrane (0.2 µm), has been shown to be effective in eliminating this loss.³⁷ Large proteins (≥ 100,000 daltons) denatured by SDS may transfer poorly due to the addition of alcohol to the transfer buffer. Alcohol increases binding of SDS-proteins to nitrocellulose, but decreases pore sizes in the gel. Elimination of alcohol from SDS-protein transfers results in considerably diminished binding. Adding SDS (up to 0.1%) to the transfer buffer increases the transfer efficiency of proteins, but reduces the amount of binding to the membrane.¹⁷ Also, SDS increases the conductivity of the buffer and the heat generated during transfer.

PVDF Membrane

PVDF (Polyvinylidene difluoride) membrane is an ideal support for amino-terminal sequencing, amino acid analysis and immunoassays of blotted proteins. PVDF retains proteins under extreme conditions of exposure to acidic or basic conditions, and in the presence of

organic solvents. Greater retention during sequencing manipulations enhances the likelihood of obtaining information from rare, low abundance proteins, by increased initial coupling and higher repetitive yields. In addition, PVDF membrane exhibits better binding efficiency of blotted material in the presence of SDS in the transfer buffer. PVDF must first be wetted in 100% MeOH but can then be used in buffer which does not contain MeOH.

5.2 DNA and RNA Blotting Membranes

Zeta-Probe® Nylon Membrane

Nitrocellulose is not a suitable medium for electrophoretic transfer of nucleic acids, as high concentrations of salt ($\geq 10 \times \text{SSC}$) are required for efficient binding.¹³ Molecules ≤ 500 bp are not bound at all, even at high salt. Low resistance results when an electric current is passed through a solution of high salt. This causes potentially damaging high currents (and power) at very low voltages. Since V/cm is the eluting force, inefficient transfer occurs under conditions required for proper binding. Zeta-Probe membrane allows efficient binding of all sizes of single stranded DNA and RNA in the presence of low ionic strength buffers.¹³ Zeta-Probe membrane is an ideal alternative to nitrocellulose for the analysis of nucleic acids. Binding is more stable through post transfer washes, and reprobing may be performed as many as 10 times.

Table 5.1 Guide to Protein Blotting Membranes

A variety of blotting membranes is available for immunoblotting, each with particular advantages depending on the needs of the experiment. The physical properties and performance characteristics of a membrane should be evaluated when selecting the appropriate transfer conditions.

Membrane	Pore Size	Binding Capacity ($\mu\text{g}/\text{cm}^2$)	Notes
Nitrocellulose	0.45 μm 0.2 μm	80–100	General purpose protein blotting membrane
Supported Nitrocellulose	0.45 μm 0.2 μm	80–100	Pure nitrocellulose cast on an inert synthetic support; increased strength for easier handling and for reprobing.
PVDF	0.2 μm	170–200	High mechanical strength and chemical stability, used for protein sequencing and western blotting; enhanced binding in the presence of SDS. Must be wet in alcohol before equilibration in buffer.
Nylon	0.2 μm	170	Recommended for nucleic acids.

Note: Nucleic acids cannot be transferred to nitrocellulose by electrophoretic blotting. Use Zeta-Probe membrane.

Section 6 Troubleshooting Guide

6.1 Electrophoretic Transfer

Poor electrophoretic transfer (as detected by staining the gel)—proteins

1. Transfer time is too short.
 - Increase the transfer time.
2. Power is too low.
 - Always check the current at the beginning of the run. The current may be too low for a particular voltage setting. If the buffer is prepared improperly, the conductivity may be too low, and not enough power will be delivered to the cell. See the power guidelines for specific applications in Section 3.
 - Remake the buffer or increase the voltage.
 - Try the high intensity blotting option.
3. Transfer apparatus is assembled incorrectly, and the proteins are moving in the wrong direction.
 - The gel/membrane sandwich may be assembled in the wrong order or the cassette is inserted in the tank facing the opposite orientation. Check the polarity of the connections to the power supply.
4. Charge-to-mass ratio is incorrect.
 - Try a more basic or acidic transfer buffer to increase protein mobility. Proteins near their isoelectric point at the pH of the buffer will transfer poorly. (It has been suggested that buffer pH should be 2 pH units higher or lower than the pI of the protein of interest for optimal transfer efficiency.)

5. Protein is precipitating in the gel.
 - Try using SDS in the transfer buffer. SDS can increase transfer efficiency, but can also reduce binding efficiency to nitrocellulose and affect reactivity of some proteins with antibodies.
6. Power supply circuit is inoperative, or an inappropriate power supply was used.
 - Check the fuse. Be sure the voltage and current output of the power supply match the needs of the blotting instrument.
7. Methanol in the transfer buffer is restricting elution.
 - Reduction of methanol results in increased transfer efficiency of proteins from the gel, but it also diminishes binding to nitrocellulose and PVDF.
8. Gel percentage too high.
 - Reduce %T (total monomer) or %C (crosslinker). A 5% C (with bis as the crosslinker) will produce the smallest pore size gel. Decreasing from this concentration will increase the pore size and increase transfer efficiency.

Poor transfer—nucleic acid

1. Gel percentage is too high.
 - Reduce the %T or %C in the acrylamide gel or reduce % agarose in an agarose gel.
 - Prior to transfer, cleave DNA in dilute 0.25 M HCl or RNA in dilute NaOH.
2. Transfer time is too short or power conditions are too low.
 - Increase the transfer time, or try high intensity transfer.
3. DNA or RNA cannot be transferred electrophoretically to nitrocellulose, since high salt concentrations are required for efficient binding.
 - Use Zeta-Probe membrane instead of nitrocellulose.

Swirls or missing bands; diffuse transfers

1. Poor contact between the membrane and the gel. Air bubbles or excess buffer remain between the blot and gel.
 - Use a test tube or pipet as a rolling pin, and roll over the membrane carefully in both directions until air bubbles and excess buffer are removed from between gel and membrane, and complete contact is established.
 - Use thicker filter paper in the gel/membrane sandwich.
 - Replace the fiber pads. Pads will compress with time, and will not hold the membrane to the gel.
2. Power conditions are too high.
 - Always check the current at the beginning of the run. The current may be too high for a particular voltage setting. If the buffer is prepared improperly, the conductivity may be too high, resulting in excessive power delivered to the cell. See the power guidelines for specific applications in Section 3.

3. The membrane is not properly wet or has dried out.
 - White spots on the nitrocellulose membrane indicate dry areas where protein will not bind. If wetting does not occur immediately by immersion of the sheet in transfer buffer, heat distilled water until just under the boiling point, and soak the membrane until completely wet. Equilibrate in transfer buffer until ready for use.
 - Because of the hydrophobic nature of PVDF, the membrane must be prewet in methanol prior to equilibration in aqueous transfer buffer. Follow the directions in the product insert.
4. The gel electrophoresis may be at fault.
 - Artifacts of electrophoresis may be produced by poor polymerization, inappropriate running conditions, contaminated buffers, sample overload, etc.

Gel cassette pattern transferred to blot

1. Contaminated or thin fiber pads are used.
 - Replace the fiber pads, or thoroughly clean the contaminated pads.
2. Excessive amounts of protein were loaded on the gel, or too much SDS was used in the transfer buffer. Proteins can pass through the membrane without binding, and recirculate through the tank blotting system.
 - Reduce the amount of protein on the gel, and SDS in the transfer buffer. Add a second sheet of membrane to bind excess protein.
3. The transfer buffer is contaminated.
 - Make fresh solutions.

Poor binding to the membrane—Nitrocellulose

1. Nitrocellulose requires 20% methanol in the transfer buffer for optimal protein binding.
 - Make sure the buffer contains the proper amount of methanol.
2. Proteins may be transferring through the nitrocellulose.
 - Use PVDF or nylon (higher binding capacities) or 0.2 μm nitrocellulose (smaller pore size). Decrease the voltage or move the electrodes to the standard position if using the high intensity option.
3. Mixed ester celluloses bind proteins poorly.
 - Use pure nitrocellulose.
4. Proteins <15,000 daltons may show diminished binding to 0.45 μm nitrocellulose, or may be washed from the membrane during assays.
 - To increase stability of binding, proteins can be crosslinked to nitrocellulose with glutaraldehyde.
 - Use PVDF or nylon membrane, which have higher binding capacities.
 - Use Tween-20 detergent in the wash and antibody incubation steps. Reduce or eliminate the more stringent washing conditions.
5. SDS in the transfer buffer will reduce binding efficiency of proteins.
 - Reduce or eliminate the SDS from the transfer buffer.

6. The membrane may not be completely wet.
 - White spots on the membrane indicate dry areas where protein will not bind. If wetting does not occur immediately by immersion of the sheet in transfer buffer, heat distilled water until just under the boiling point, and soak the membrane until completely wet. Equilibrate in transfer buffer until ready for use.

Poor binding to the membrane—PVDF

1. The membrane may not be completely wet.
 - Because of the hydrophobic nature of PVDF, the membrane must be prewet in alcohol prior to equilibration in aqueous transfer buffer. Follow the directions in the product insert.
2. The membrane may have been allowed to dry during handling.
 - A completely wet membrane has a gray, translucent appearance. White spots will form on the surface of the membrane, indicating that it has been allowed to dry. Since proteins will not bind to the dry spots, rewet the membrane with methanol and re-equilibrate in transfer buffer.

6.2 Immune-Specific Detection

Overall high background

1. Blocking conditions are inappropriate.
 - Match the blocker to the membrane. For example, nylon and PVDF membranes require more extensive blocking, usually with non-fat dry milk.
 - Increase the concentration or blocking time as necessary.
 - The blocker must be a pure protein. The blocker may be contaminated with material that binds probes non-specifically.
2. Insufficient wash protocols are used.
 - Increase the number, duration, or stringency of the washes. Include progressively stronger detergents in the washes, *e.g.* SDS is stronger than NP-40 which is stronger than Tween-20. Also, include Tween-20 in the antibody dilution buffers to reduce non-specific binding.
3. The blot is left in the substrate too long.
 - Remove the blot from the substrate solution when the signal-to-noise level is acceptable. Do not overdevelop. Stop the reaction immediately by immersing the blot in dd H₂O.
4. Contamination occurred during a previous step, *e.g.* electrophoresis or transfer.
 - Discard and remake the gel and transfer solutions.
 - Replace or thoroughly clean contaminated fiber pads. Excessive amounts of protein were loaded on the gel, or too much SDS was used in the transfer buffer. Proteins can pass through the membrane without binding and recirculate through a tank blotting system. Reduce the amount of protein on the gel or SDS in the transfer buffer. Add a second sheet of membrane to bind excess protein.

5. Primary or secondary antibody is too concentrated.
 - Increase the dilution of the antibodies. Perform a dot-blot experiment to optimize the working concentrations.
6. Incubation trays are contaminated.
 - Clean the trays or use disposable trays.

Nonspecific reactions between bound proteins and probes

1. Primary or secondary antibody is contaminated with nonspecific or species cross-reactive IgG.
 - Use purified IgG first antibody fractions and affinity-purified blotting grade secondary antibody.
2. Monoclonal antibodies may react non-specifically with SDS denatured proteins.
 - Compare the binding of other monoclonal or polyclonal antibodies.
 - Blot native proteins as a comparison.
3. Nonsense interactions are occurring due to ionic associations. For example, avidin, a glycosylated protein, may bind to more acidic proteins on blots.
 - Increase the ionic strength of the incubation buffers. Increase the number, duration, or stringency of the washes. Include progressively stronger detergents in the washes, *e.g.* SDS is stronger than NP-40 which is stronger than Tween-20. Include Tween-20 in the antibody dilution buffers to reduce nonspecific binding.

No reaction or weak signal

1. The sample load was insufficient.
 - Increase the amount of protein applied. Concentration of the sample prior to loading may be necessary. Use a more sensitive assay system.
2. Insufficient antigen binding to the membrane is occurring.
 - Stain the gel after transfer or use prestained or Kaleidoscope standards to assess transfer efficiency. See the previous section for suggestions on improving transfer related problems.
3. Primary or secondary antibodies may be inactive or non-saturating.
 - Store the reagents at recommended conditions. Avoid repeated freeze-thaw cycles, bacterial contamination, or heat inactivation.
 - Detergents may affect the activity of some antibodies. Eliminate them from the assay, except for the wash after blocking.
 - If the antibody titer is too low, optimize the concentration using a dot-blot experiment.
 - Increase the antibody incubation times.
4. The enzyme conjugate is inactive or non-saturating.
 - Test the reagent for activity (see below).
 - Store the reagents at recommended conditions. Avoid repeated freeze-thaw cycles, bacterial contamination, or heat inactivation.

- Sodium azide is a potent inhibitor of horseradish peroxidase. Use Thimerosal as a bacteriostat.
 - Impure water may cause inactivation of the enzyme. Use only distilled, deionized water.
 - If the conjugate concentration is too low, optimize using a dot-blot experiment.
5. Color development reagent is inactive.
 - Test the reagent for activity (see below) and remake if necessary.

Tests for monitoring reagent activity

1. Activity test for the color development solution.
 - Combine 1.0 ml of the color development solution with 10 μ l of full strength second antibody conjugate. The color reaction should develop immediately. If color fails to develop within a few minutes, the color development solution is inactive. Make up a fresh working solution and repeat the color development assay.
2. Activity test for the conjugate solution.
 - Combine 1.0 ml of the color development solution tested above and 1.0 ml of the 1:3,000 dilution conjugate solution. A light blue tinge should develop within 15 minutes. If color fails to develop within 25 minutes, the conjugate solution is suspect. Repeat the procedure with a freshly prepared dilution of conjugate.
3. Activity test for the first antibody solution.
 - Use an ELISA, RID, Ouchterlony immunodiffusion, or precipitation test to determine reactivity of the antibody with the antigen. If possible, repeat the assay procedure with several dilutions of first antibody solution.

6.3 Total Protein Detection

Colloidal Gold Total Protein Stain—high background

1. The blocking step is insufficient or omitted.
 - Block with 0.3% Tween-20 in TBS, using three washes of 20 minutes each.
2. The membrane used is not compatible with this stain.
 - Positively charged nylon membranes cannot be used with Colloidal Gold stain. Use the Biotin-Blot Total Protein Detection Kit instead.
3. Contamination of the membrane occurred at a previous step, *i.e.* electrophoresis or transfer.
 - Discard and remake the gel and transfer solutions.
 - Replace or thoroughly clean contaminated fiber pads.
4. Excessive amounts of protein are loaded on the gel, or too much SDS is used in the transfer buffer. Proteins can pass through the membrane without binding and recirculate through a tank blotting system
 - Reduce the amount of protein on the gel or SDS in the transfer buffer. Add a second sheet of membrane to bind excess protein.
5. Colloidal gold stain solution is contaminated.

- The stain is a reusable reagent. Be sure to use a separate, clean plastic container to store previously used reagent in the refrigerator. Discard any reagent that has viscous sediment at the bottom of the bottle. If the solution does not have a dark burgundy color, but is a light blue, the stain was contaminated with buffer salts. Buffer salts will react with the gold sol causing non-specific precipitation of the reagent onto the membrane. Discard this solution.

Colloidal Gold Total Protein Stain—low sensitivity

1. Increase the incubation time for detection of low level signals.
 - Overnight incubations are possible, although background staining can increase.
2. Transfer is incomplete.
 - See poor transfer for suggestions on how to enhance transfer efficiency.
3. Stain is exhausted, as evidenced by the loss of the dark burgundy color and longer staining times.
 - Discard the reagent.
4. Buffer salt contamination has occurred. The solution will be light blue instead of dark burgundy.
 - Discard the reagent.
5. The sample load may be too low for the reagent to detect.
 - Use the Gold Enhancement Kit for detection levels as low as 10 pg of protein per band.

Biotin-Blot Total Protein Detection—high background

1. Blocking conditions are insufficient.
 - Match the blocker to the membrane. Nylon membranes require the addition of 1-methyl-2-pyrrolidinone (MPO) to several solutions. Consult the Biotin-Blot manual for specific details.
2. Membrane is left in color development solution too long.
 - Remove the membrane from the color development solution when the signal is apparent and the background has not developed. Transfer the blot to distilled water immediately to stop the development.
3. Excessive amounts of protein are loaded on the gel, or too much SDS is used in the transfer buffer. Proteins can pass through the membrane without binding and recirculate through a tank blotting system
 - Reduce the amount of protein on the gel or SDS in the transfer buffer. Add a second sheet of membrane to bind excess protein.

Biotin-Blot Total Protein Detection—no reaction or weak color development

1. Transfer is incomplete.
 - See Poor Transfer for suggestions on how to enhance transfer efficiency.
2. The sample load may be too low for the reagents to detect.
 - Increase the amount of protein loaded on the gel.

3. NHS-biotin solution is inactivated.
 - NHS-biotin hydrolyzes in aqueous solutions. Equilibrate the reagent vial to room temperature before opening to prevent condensation of water inside the container. Use a sterile syringe to remove reagent to prevent contamination.
 - Add the NHS-biotin reagent to the Borate-Tween solution just prior to use.
4. Amine containing buffer salts compete for the biotinylation reagents.
 - Wash the membrane thoroughly in Borate-Tween to remove any residual buffer salts from electrophoresis and transfer.
5. Avidin-HRP conjugate is inactive.
 - Follow the activity test procedures to determine if the reagent is inactive.
6. Color development solution is inactive.
 - Follow the activity test procedures to determine if the reagent is inactive.

Anionic dyes—high background

1. Destaining is insufficient.
 - Increase the number and duration of washes with the destaining solution.
2. Dye solution is too concentrated.
 - Remake the solution.
3. Nylon membranes are not compatible with anionic dyes.
 - Use the Biotin-Blot Protein Detection Kit.

Anionic dyes—low sensitivity

1. Anionic dye stains do not detect protein bands below ~100 ng.
 - Use a more sensitive stain such as the Colloidal Gold stain or the Biotin-Blot Protein Detection Kit.
 - Increase the sample load to achieve the detection level of the anionic dye stains.

Section 7 Product Information

Catalog Number	Product Description
Mini Trans-Blot Cell	
170-3930	Mini Trans-Blot Electrophoretic Transfer Cell , includes 2 Gel Holder cassettes, modular electrode assembly, Bio-Ice cooling unit, lower buffer chamber, and lid with cables
170-3935	Mini Trans-Blot Module , same as 170-3930 without lower buffer chamber and lid
Mini Trans-Blot Cell Accessories	
170-3931	Mini Gel Holder Cassette
170-3932	Filter Paper , 7.5 x 10.5 cm, 50
170-3933	Fiber Pads , 8 x 11 cm, 4
170-3934	Bio-Ice Cooling Unit

Section 8 References

1. Southern, E. M., *J. Mol. Biol.*, **98**, 503 (1975).
2. Alwine, J. C., Kemp, D. J., Parker, B. A., Reiser, J., Renart J., Stark, G. R. and Wahl, G. W., *Methods Enzymol.*, **68**, 220 (1979).
3. Thomas, P. S., *Proc. Nat. Acad. Sci.*, **77**, 5201 (1980).
4. Seed, B., *Nuc. Acids Res.*, **10**, 1799 (1982).
5. Renart, J., Reiser, J. and Stark, G. R., *Proc. Nat. Acad. Sci.*, **76**, 3116 (1979).
6. Bowen, P., Steinberg, J., Laemmli, U. K. and Weintraub, H., *Nuc. Acids Res.*, **8**, 1 (1980).
7. Towbin, H., Staehelin, T. and Gordon, J., *Proc. Nat. Acad. Sci.*, **76**, 4350 (1970).
8. Bittner, M., Kupferer, P. and Morris, C. R., *Anal. Biochem.*, **102**, 459 (1980).
9. Stellwag, E. J. and Dahlberg, A. E., *Nuc. Acids Res.*, **8**, 299 (1980).
10. Kutateladze, T. V., Axelrod, B. D., Gorbulev, V. G., Belzhelarshaya, S. N. and Vartikyan, R. M., *Anal. Biochem.*, **100**, 129 (1979).
11. Peudelhuber, T. L., Ball, D. J., Davis, A. H. and Garrard, W. J., *Nuc. Acids Res.*, **10**, 1311 (1982).
12. Danner, D. B., *Anal. Biochem.*, **125**, 139 (1982).
13. Bio-Rad Technical Bulletin 1110 "Zeta-Probe Blotting Membranes" (1982).
14. Holland, L. J. and Wangh, L. H., *Nuc. Acids Res.*, **10**, 3283 (1983).
15. Syminton, J., Green, M. and Brackmann, K., *Proc. Nat. Acad. Sci.*, **78**, 177 (1981).
16. Reiser, J. and Wardale, J., *Eur. J. Biochem.*, **114**, 569 (1981).
17. Burnette, W. N., *Anal. Biochem.*, **112**, 195 (1981).
18. Legocki, R. P. and Verma, D. P. S., *Anal. Biochem.*, **111**, 385 (1981).
19. Lin, W. and Kasamatsu, H., *Anal. Biochem.*, **128**, 302 (1983).
20. Anderson, N. L., Nance, S. L., Pearson, T. W. and Anderson, N. G., *Electrophoresis*, **3**, 135 (1982).
21. McLellan, T. and Pamshaw, J. A. M., *Biochem. Genetics*, **19**, 647 (1981).
22. Gibson, W., *Anal. Biochem.*, **118**, 1 (1981).

23. Howe, J. G. and Hershey, J. W. B., *J. Biol. Chem.*, **2566**, 12836 (1981).
24. Erickson, P. G., Minier, L. N. and Lasher, P. S., *J. Immun. Meth.*, **51**, 241 (1982).
25. Tsang, V. C. W., Peralta, J. M. and Simons, A. R., *Meth. Enzymol.*, **92**, 377 (1983).
26. Gershoni, J. M. and Palade, G. E., *Anal. Biochem.*, **124**, 396 (1982).
27. Gershoni, J. M. and Palade, G. E., *Anal. Biochem.*, **131**, 1 (1983).
28. Symington, J., "Two Dimensional Gel Electrophoresis of Proteins: Methods and Applications." Celis, J. E. and Bravo, R., eds. Academic Press, N.Y., (1983).
29. Andrews, A. T., "Electrophoresis: Theory, techniques, and biochemical and clinical application," 2nd ed., Clarendon Press, Oxford, (1986).
30. Beisiegel, V., *Electrophoresis*, **7**, 1 (1986).
31. Bio-Rad Laboratories, unpublished.
32. Gershoni, J. M., in *Advances in Electrophoresis*, Vol. 1. Chrambach, A., Dunn, M. J. and Radola, B. J., eds., VCH, Weinheim, in press.
33. Gershoni, J. M., in *Methods of Biochemical Analysis*, Vol. 33, Glick, D., ed., Wiley, New York, in press.
34. Bjerrum, O. J. and Schafer-Nielsen, C., *Analytical Electrophoresis*, M. J. Dunn, ed. (VCH, Weinheim), p. 315.
35. Dunn, S. D., *Anal. Biochem.*, **157**, 144 (1986).
36. Zeta-Probe Instruction Manual, Bio-Rad Laboratories, (1988).
37. Polvino, W. J., Saravis, C. A., Sampson, C. E. and Cook, R. B., *Electrophoresis*, **4**, 368 (1983).
39. Bio-Rad Laboratories, Biotin-Blot Total Protein Stain Instruction Manual (1985).
40. LaRoche, W. J. and Froehner, S. C., *J. Immunol. Meth.*, **92**, 65 (1986).
41. Szewczyk, B. and Kozloff, L. M., *Anal. Biochem.*, **150**, 403 (1985).
42. Perides, G., Plagens, U. and Traub, P., *Anal. Biochem.*, **152**, 94 (1986).

Scotch-Brite® is a registered trademark of 3M Company.

Gel-Bond™ is a trademark of FMC.

Mylar® is a registered trademark of E.I. DuPont de Nemours Co.

Coomassie is a trademark of ICI.



BIO-RAD

Declaration of Conformity

Bio-Rad Laboratories, Inc., 1000 Alfred Nobel Drive, Hercules, California, 94547, U.S.A., declares that the product

Mini Trans-Blot Electrophoretic Cell

to which this declaration relates, is in conformity to the following standards or normative documents

EN55011:1991
EN50082-2:1994
EN61000-4-2:1995
ENV50141:1994
ENV50140:1994
EN61000-4-4:1995
EN61000-4-8:1995
EN61010-1:1993

following the provisions of the 89/336/EEC & 73/23/EEC Directive.

The product is imported into the EU by Bio-Rad Laboratories Ltd., Bio-Rad House, Maylands Avenue, Hemel Hempstead (London area), Hertfordshire HP2 7TD England.

29 November, 1995
date of issue



Burton Zabin
Vice President

BIO-RAD**Bio-Rad
Laboratories****Life Science
Group**

2000 Alfred Nobel Drive
Hercules, California 94547
Telephone (510) 741-1000
Fax: (510) 741-5800

Australia, Bio-Rad Laboratories Pty Limited, Block Y Unit 1, Regents Park Industrial Estate, 391 Park Road, Regents Park, NSW 2143 • Phone 02-9414-2800 • Fax 02-9914-2888
Austria, Bio-Rad Laboratories Ges.m.b.H., Auhofstrasse 78D, 1130 Wien • Phone (1) 877 89 01 • Fax (1) 876 56 29
Belgium, Bio-Rad Laboratories S.A./N.V., Begoniastraat 5, 9810 Nazareth Eke • Phone 09-385 55 11 • Fax 09-385 65 54
Canada, Bio-Rad Laboratories (Canada) Ltd., 5671 McAdam Road, Mississauga, Ontario L4Z 1N9 • Phone (905) 712-2771 • Fax (905) 712-2990
China, Bio-Rad Laboratories, 14, Zhi Chun Road, Hai Dian District, Beijing 100088 • Phone (01) 2046622 • Fax (01) 2051876
Denmark, Bio-Rad Laboratories, Symbion Science Park, Fruebjergvej 3, DK-2100 Copenhagen • Phone 39 17 9947 • Fax 39 27 1698
Finland, Bio-Rad Laboratories, Business Center Länsikeskus, Pihatörmä 1A SF-02240, Espoo, • Phone 90 804 2200 • Fax 90 804 1100
France, Bio-Rad S.A., 94/96 rue Victor Hugo, B.P. 220, 94 203 Ivry Sur Seine Cedex • Phone (1) 49 60 68 34 • Fax (1) 46 71 24 67
Germany, Bio-Rad Laboratories GmbH, Heidemannstraße 164, D-80939 München/Postfach 450133, D-80901 München • Phone 089 31884-0 • Fax 089 31884-100
India, Bio-Rad Laboratories, C-248 Defence Colony, New Delhi 110 024 • Phone 91-11-461-0103 • Fax 91-11-461-0765
Italy, Bio-Rad Laboratories S.r.l., Via Cellini, 18/A, 20090 Segrate Milano • Phone 02-21609 1 • Fax 02-21609-399
Japan, Nippon Bio-Rad Laboratories, 7-18, Higashi-Nippori 5-Chome, Arakawa-ku, Tokyo 116 • Phone 03-5811-6270 • Fax 03-5811-6272
The Netherlands, Bio-Rad Laboratories B. V., Fokkerstraat 10, 3905 KV Veenendaal • Phone 0318-540666 • Fax 0318-542216
New Zealand, Bio-Rad Laboratories Pty Ltd., P. O. Box 100-051, North Shore Mail Centre, Auckland 10 • Phone 09-443 3099 • Fax 09-443 3097
Pacific, Bio-Rad Laboratories, Unit 1111, 11/F., New Kowloon Plaza, 38, Tai Kok Tsui Road, Tai Kok Tsui, Kowloon, Hong Kong • Phone 7893300 • Fax 7891257
Singapore, Bio-Rad Laboratories (Singapore) Ltd., 221 Henderson Rd #05-19, Henderson Building, Singapore 0315 • Phone (65) 272-9877 • Fax (65) 273-4835
Spain, Bio-Rad Laboratories, S. A. Avda Valdelaparra 3, Pol. Ind. Alcobendas, E-28100 Alcobendas, Madrid • Phone (91) 661 70 85 • Fax (91) 661 96 98
Sweden, Bio-Rad Laboratories AB, Gärdsvägen 7D, Box 1276, S-171 24 Solna • Phone 46-(0)8-735 83 00 • Fax 46-(0)8-735 54 60
Switzerland, Bio-Rad Laboratories AG, Kanalstrasse 17, Postfach, CH-8152 Glattbrugg • Phone 01-809 55 55 • Fax 01-809 55 00
United Kingdom, Bio-Rad Laboratories Ltd., Bio-Rad House, Maylands Avenue, Hemel Hempstead, Herts HP2 7TD • Free Phone 0800 181134 • Fax 01442 259118